

E5 BT A18

E5 BT A12

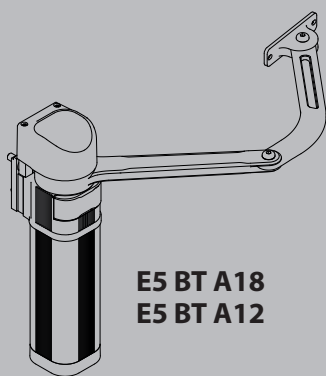

24 V



E5 BT A18
E5 BT A12

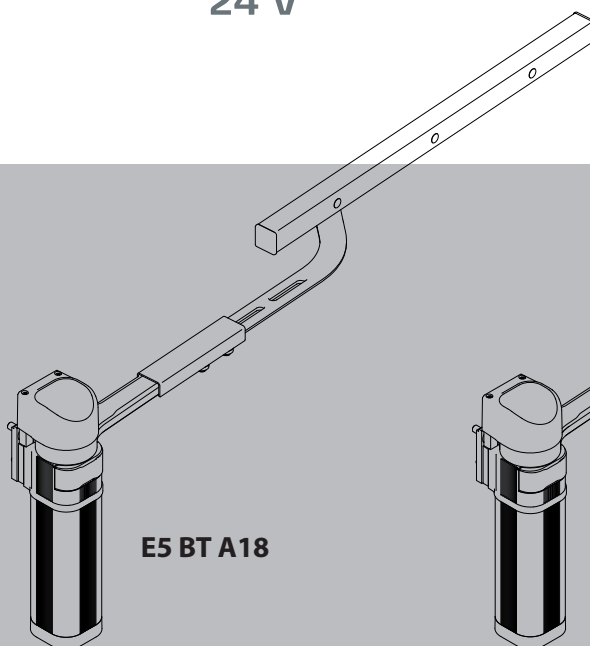

E5 BT A18

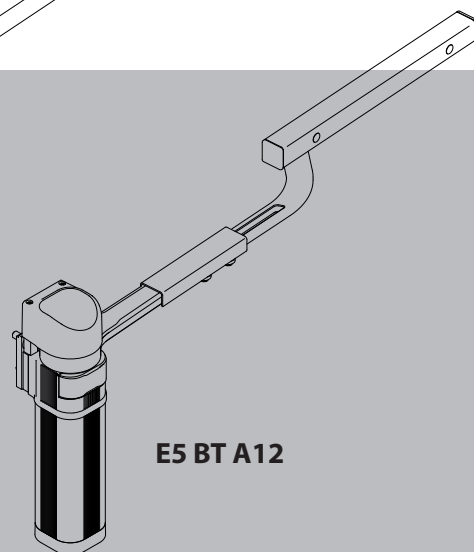

E5 BT A12

D814068 0AA00_04 19-03-20

INSTALLATION AND USER'S MANUAL

ARM AUTOMATIONS FOR SWING GATES

Caution! Read "Warnings" inside carefully!



AZIENDA CON
SISTEMA DI GESTIONE
CERTIFICATO DA DNV GL
= ISO 9001 =
= ISO 14001 =



1) IN GENERAL

The E5 automation consists of a compact electromechanical gearmotor of minimum size, which can be applied on any pillar or column, due to its versatility. The locking of the gate at closing is ensured by an electric lock, and the manual emergency manoeuvre can be easily performed, after having unlocked the electric lock using the personalised key provided, thanks to the reversibility of the gear motor.

Total safety against crushing is ensured by a multiple disc clutch, and the end-of-stroke operation is regulated with an encoder.

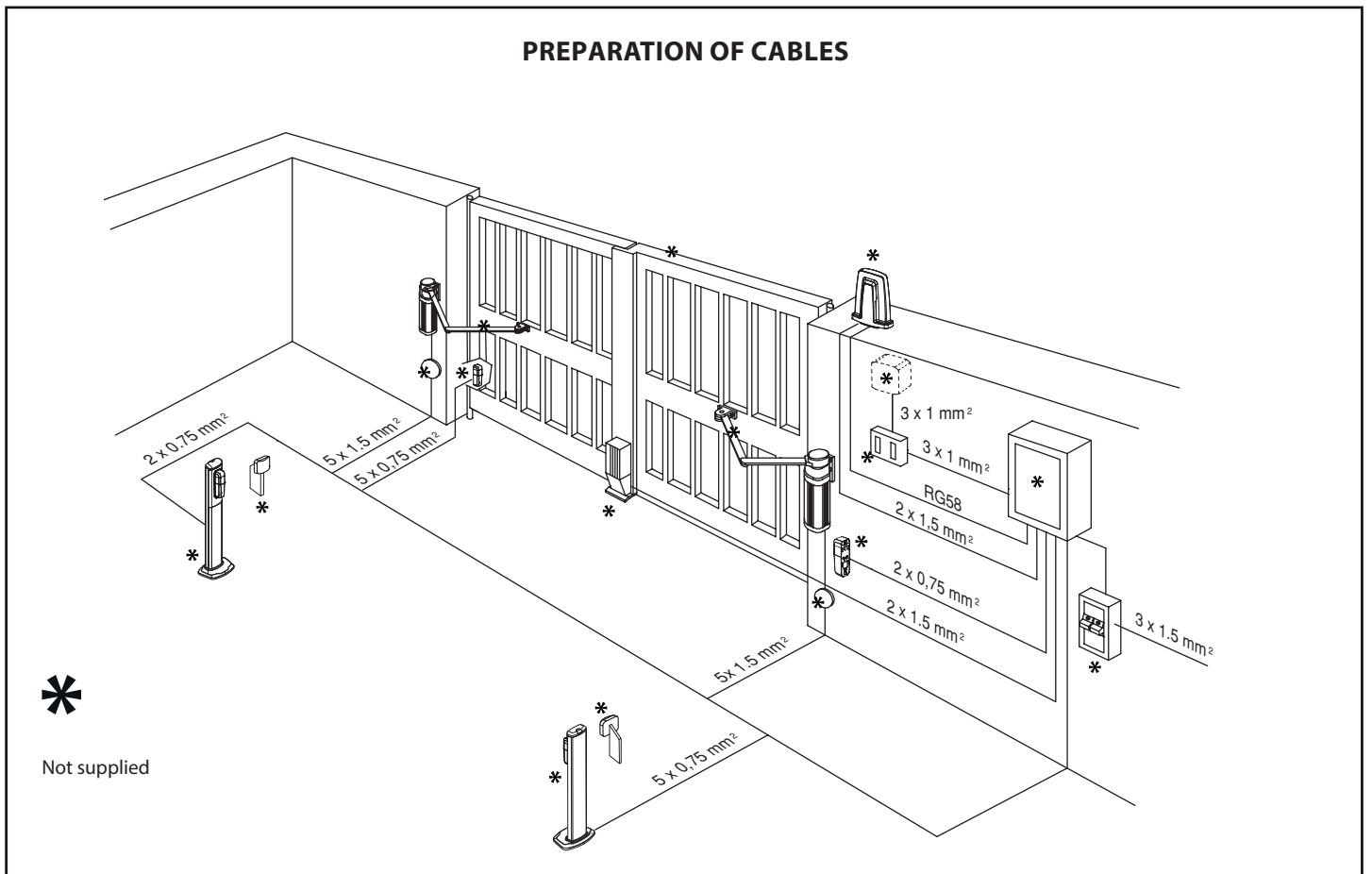

PACKAGE CONTENTS

E5 BT A18 E5 BT A12

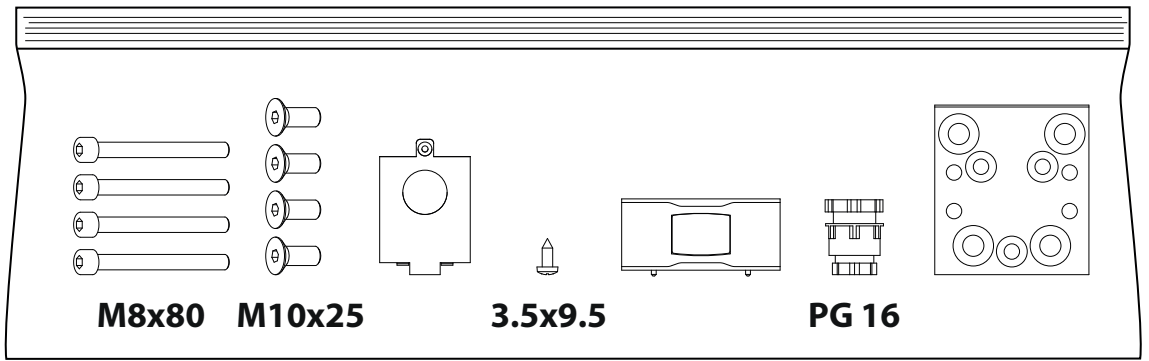
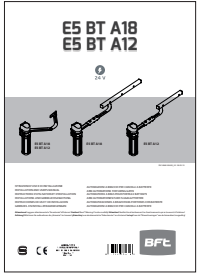
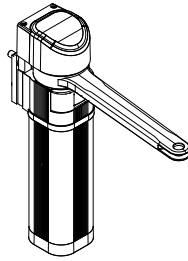

M8x80

M10x25

3.5x9.5

PG 16

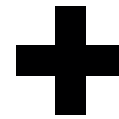
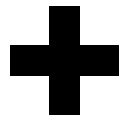

E5 BT A18

E5 BT A12

E5 BT A18

E5 BT A12

ACCESSORY ARM NOT SUPPLIED

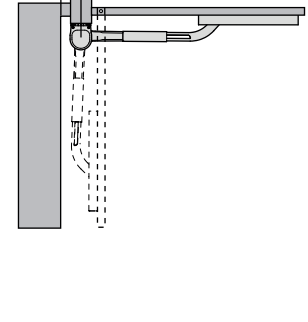
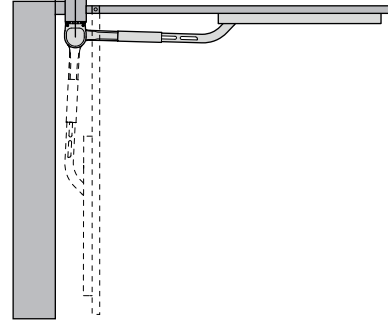
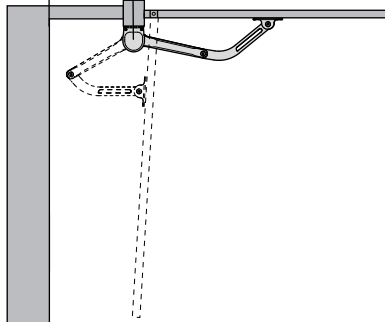
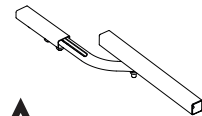
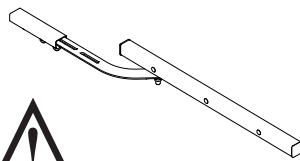

articulated arm

slide arm

slide arm

EQUIPMENT REQUIRED

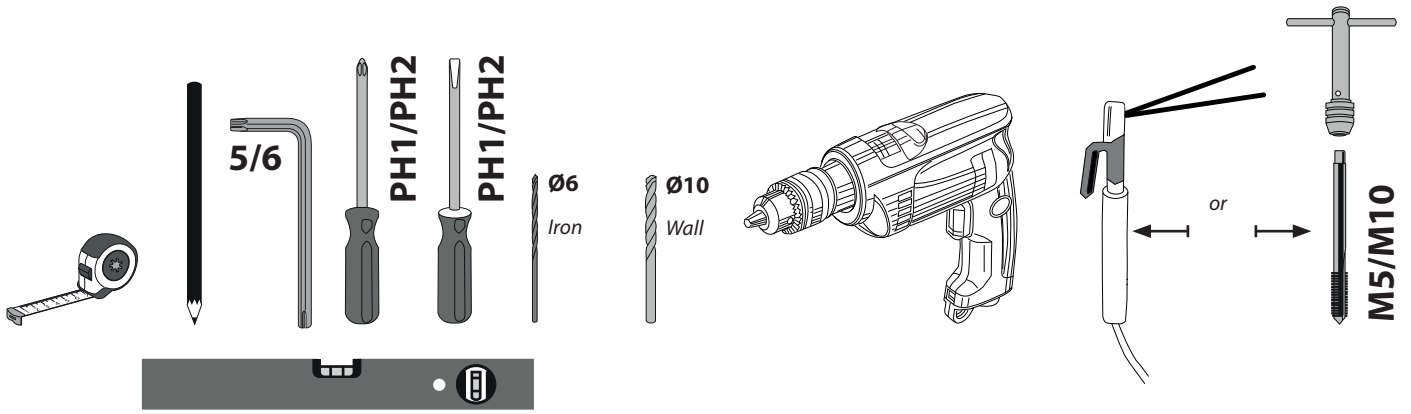

DIMENSIONS

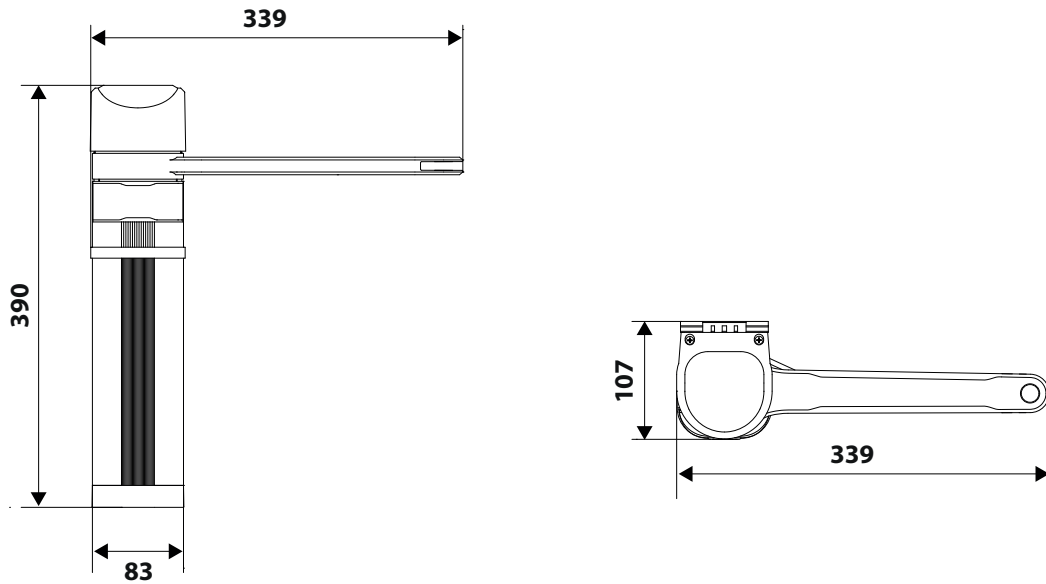

ACCESSORY ARTICULATED ARM FOR E5 BT A18 / E5 BT A12

PACKAGE CONTENTS

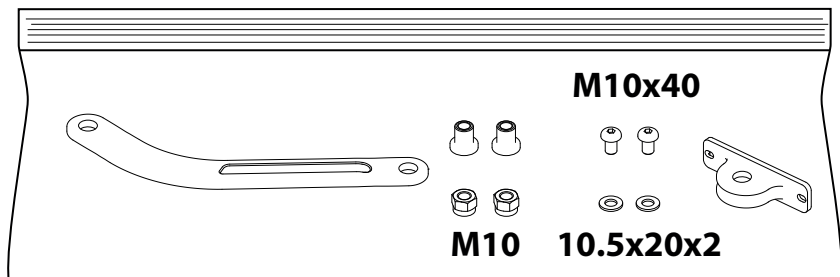

EQUIPMENT REQUIRED

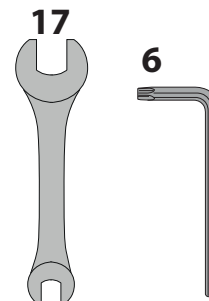

DIMENSIONS

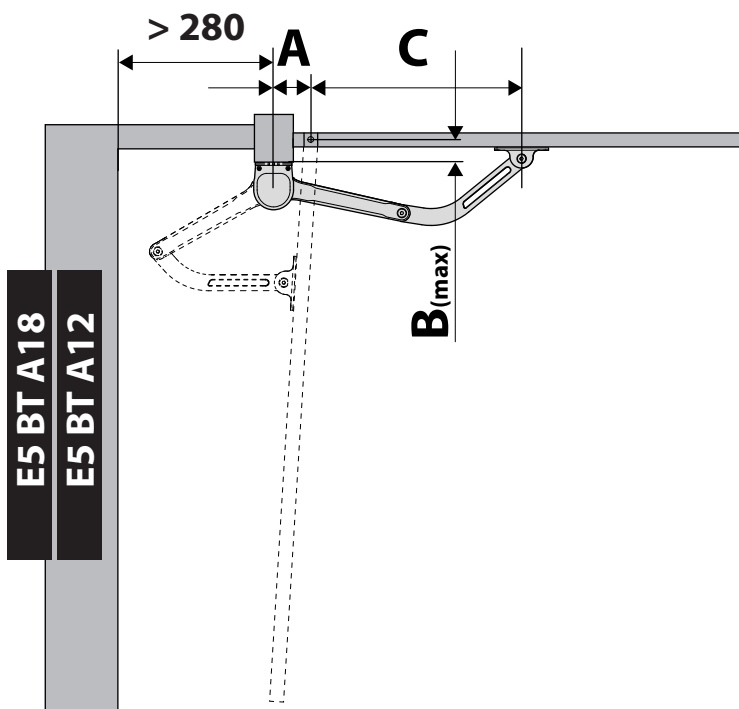

A+C 470 ÷ 530

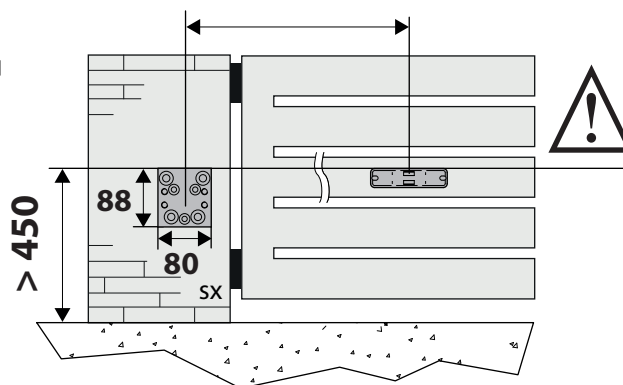

WARNING! Place the bracket on the full part of the gate.

		A							
		120	140	150	160	170	180	190	200
B	30	125°	130°	134°	134°	137°	139°	141°	142°
	40	122°	128°	130°	133°	135°	137°	139°	140°
	50	120°	126°	128°	131°	133°	135°	136°	138°
	60	118°	124°	125°	130°	131°	133°	134°	136°
	70	116°	122°	124°	128°	129°	131°	132°	134°
	80	114°	120°	123°	127°	128°	129°	130°	132°
	90	113°	118°	122°	125°	126°	127°	128°	130°
	100	112°	117°	120°	124°	124°	125°	127°	128°
	110	110°	116°	119°	122°	122°	123°	125°	126°
	120	109°	114°	118°	121°	121°	121°	123°	124°
	130	108°	113°	115°	119°	119°	120°	121°	122°
	140	107°	112°	115°	118°	117°	118°	119°	120°
	150	107°	111°	114°	116°	116°	116°	117°	118°
	160	106°	110°	113°	115°	114°	114°	116°	117°
	170	105°	109°	112°	114°	112°	113°	114°	115°
	180	104°	109°	110°	112°	111°	111°	112°	113°
	190	104°	108°	110°	111°	109°	109°	110°	111°
200	103°	107°	107°	110°	108°	108°	109°	110°	

ACCESSORY SLIDE ARM FOR E5 BT A18

PACKAGE CONTENTS

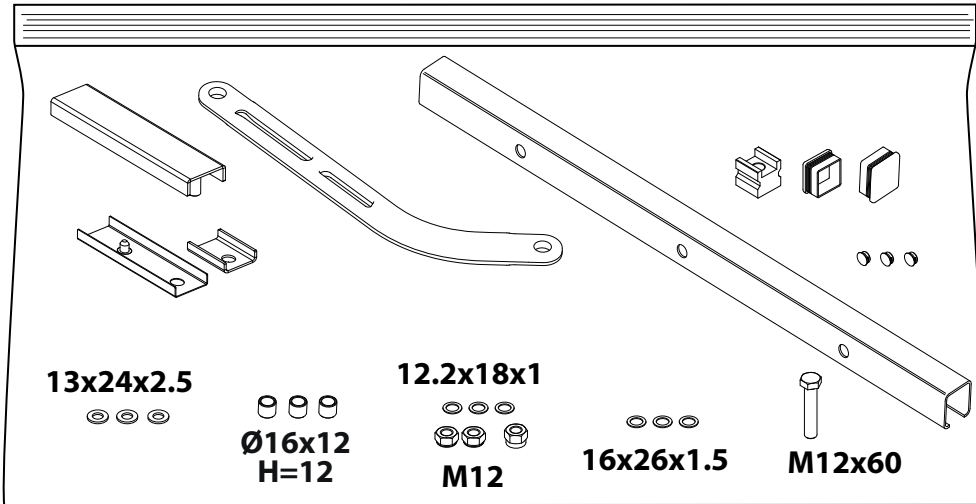

EQUIPMENT REQUIRED

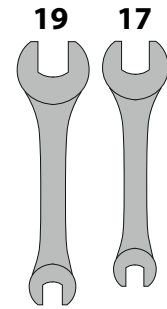

DIMENSIONS

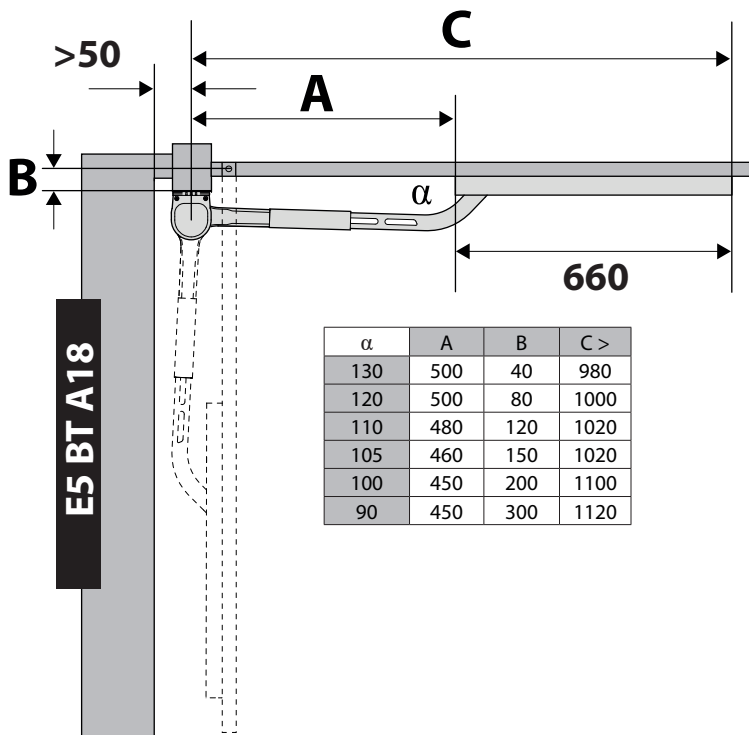

α	A	B	C >
130	500	40	980
120	500	80	1000
110	480	120	1020
105	460	150	1020
100	450	200	1100
90	450	300	1120

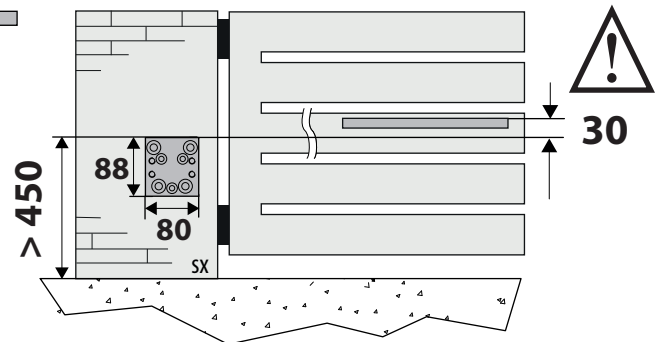

WARNING! Place the bracket on the full part of the gate.

ACCESSORY SLIDE ARM FOR E5 BT A12

PACKAGE CONTENTS

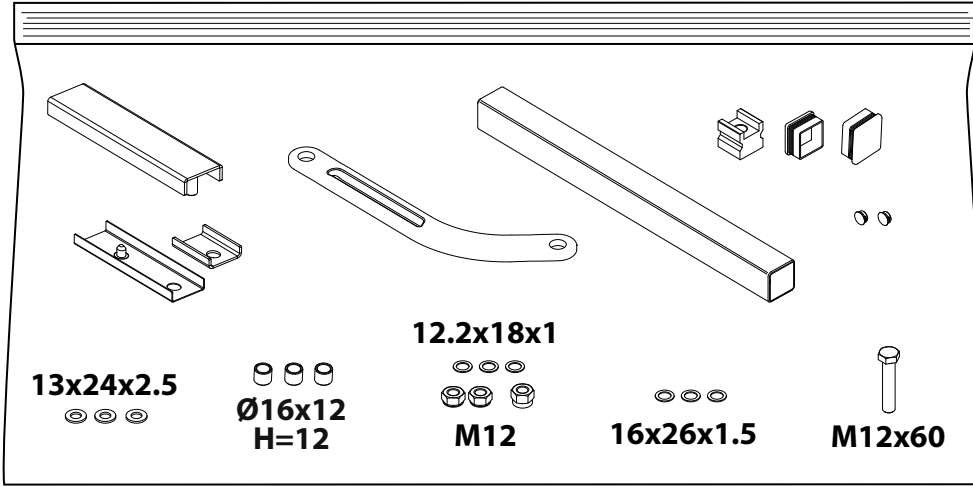

EQUIPMENT REQUIRED

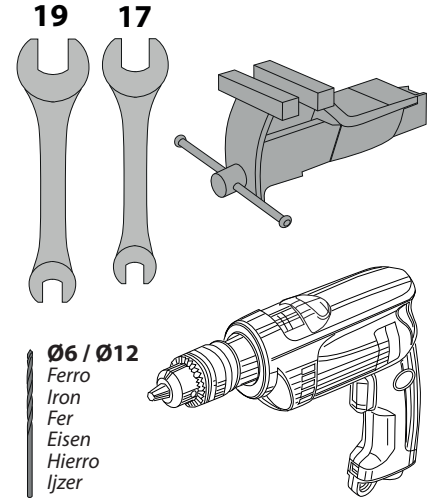

DIMENSIONS

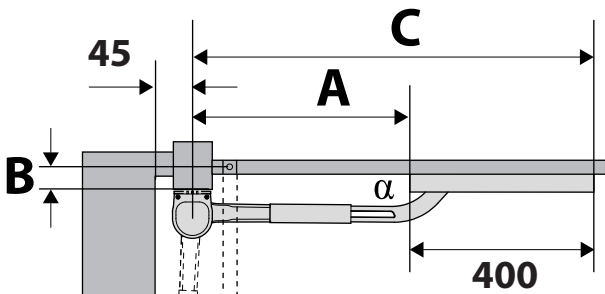

α	A	B	C >
130	450	40	910
120	450	80	930
110	450	110	950
105	430	140	990
100	430	180	1010
90	410	200	1030

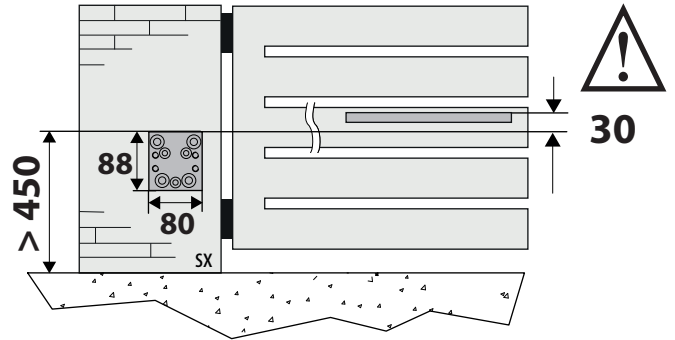

WARNING! Place the bracket on the full part of the gate.

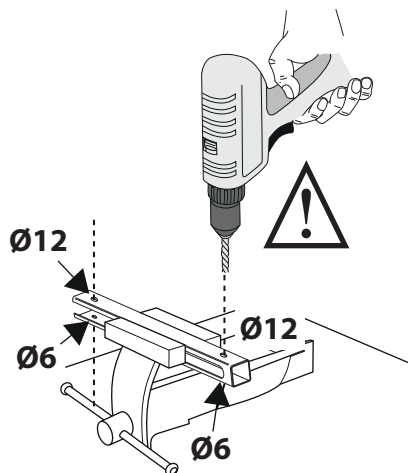

A

FASTENING OF MOTOR HOLDER PLATE

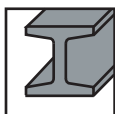
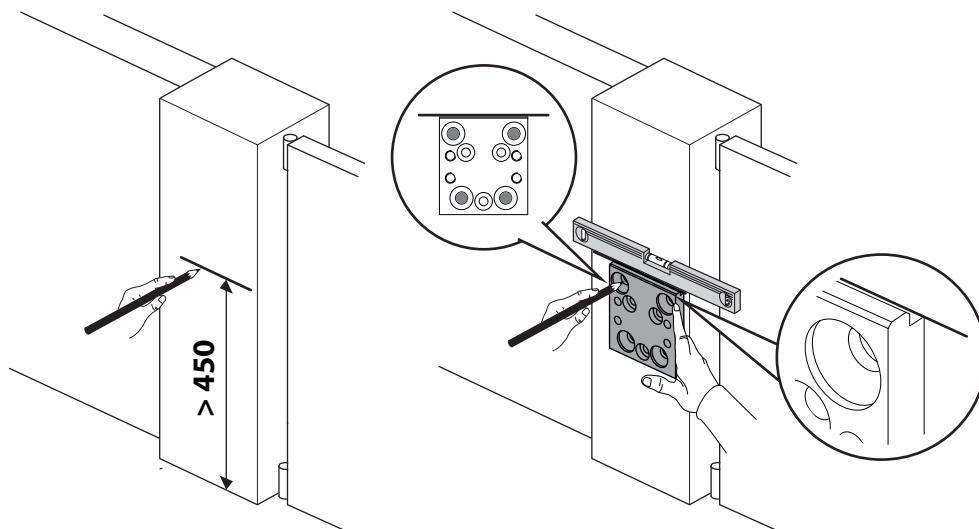
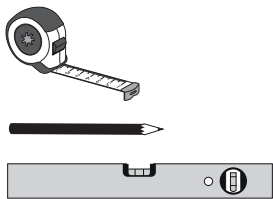

ON METAL

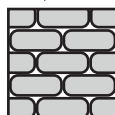
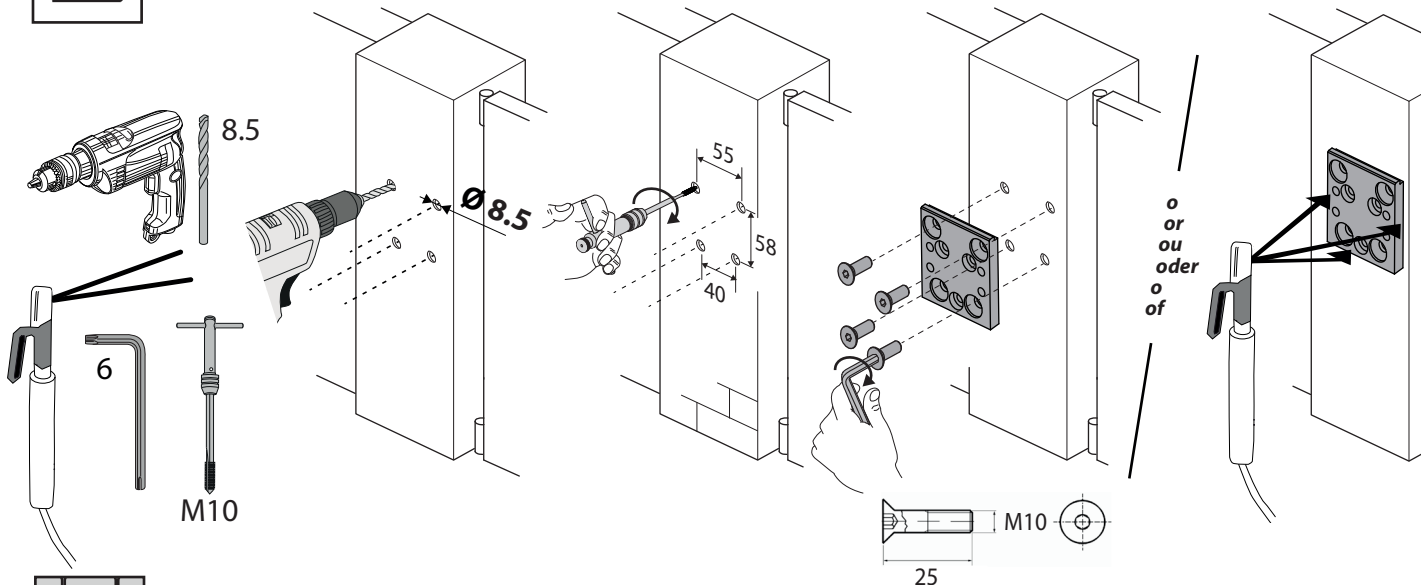

ON THE WALL

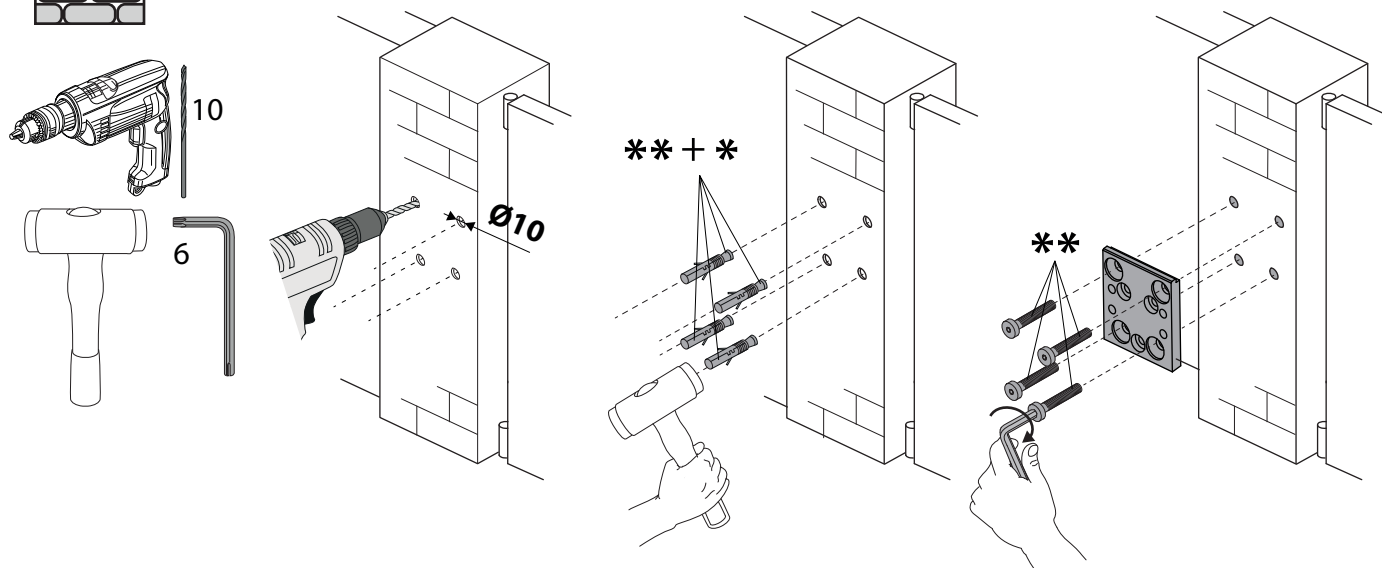

* Use stainless steel dowels!

** Not supplied!

B

FASTENING OF BRACKET ON LEAF

ARTICULATED ARM

E5 BT A18

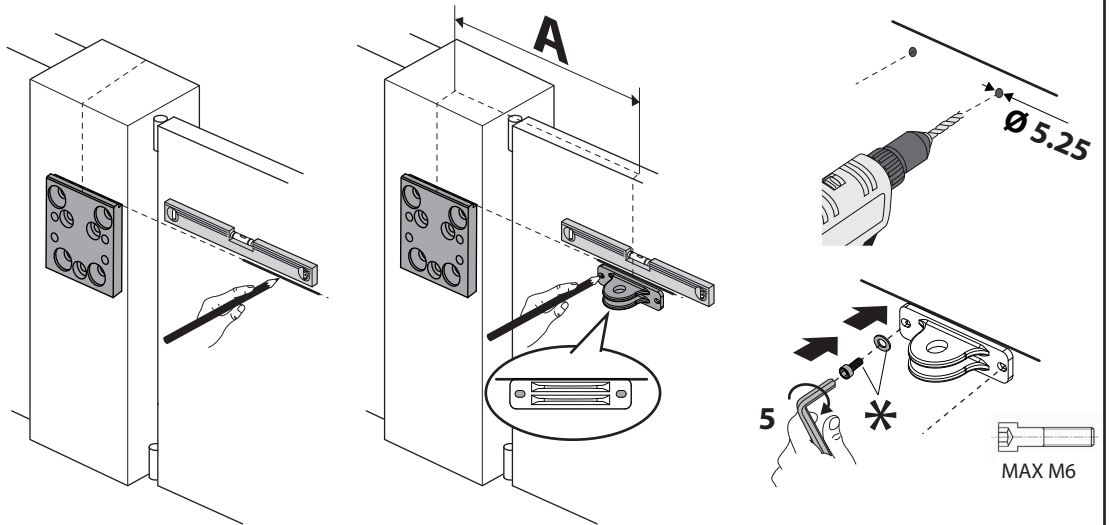
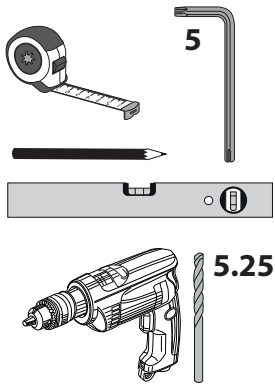

SLIDE ARM

E5 BT A18

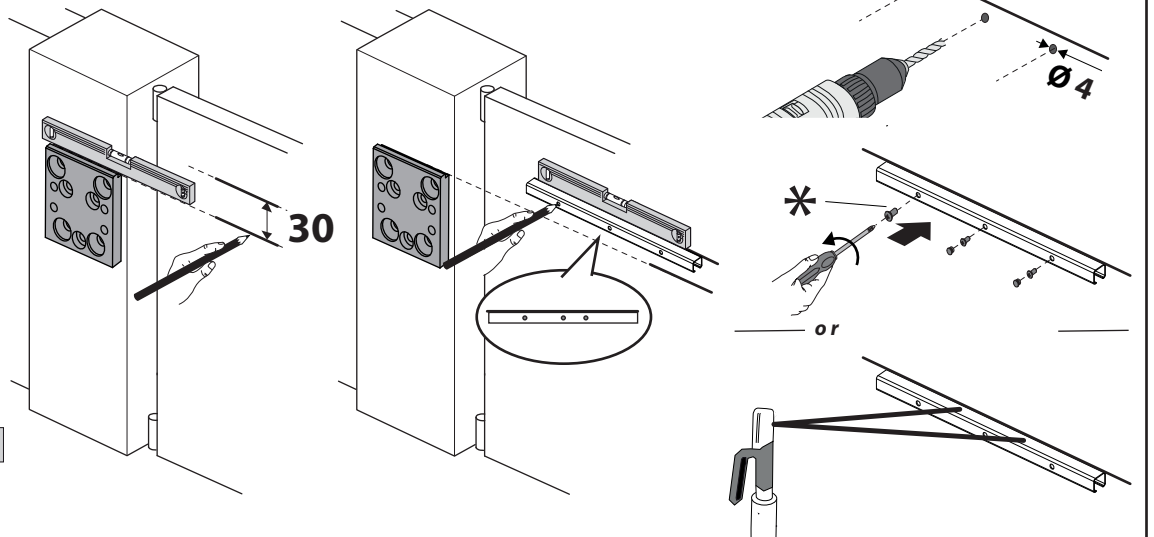
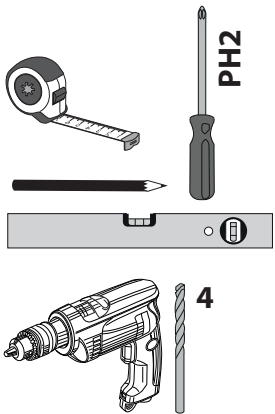

E5 BT A12

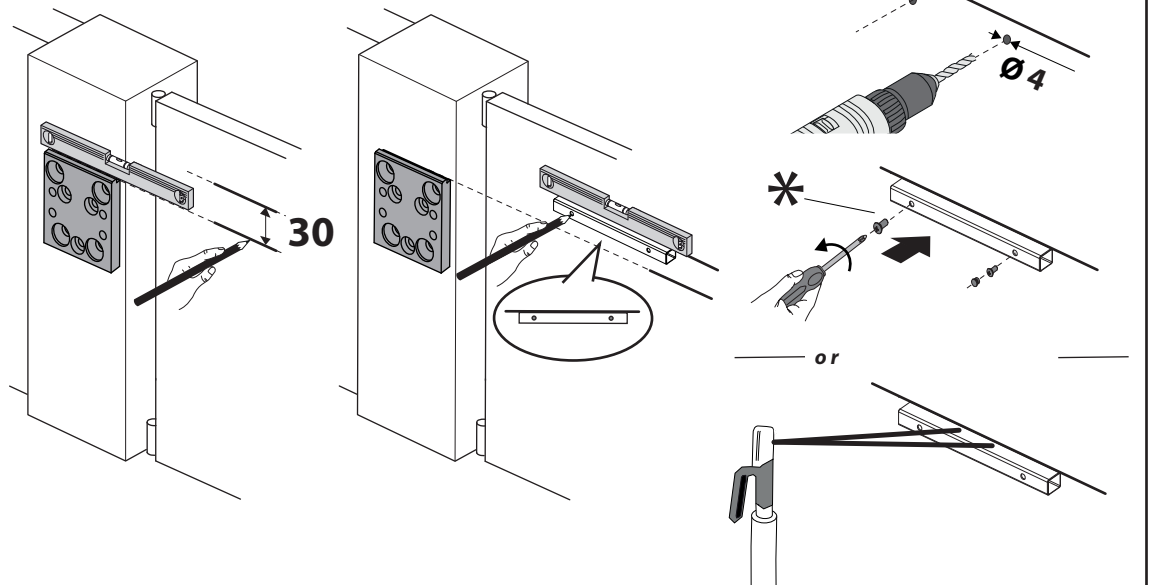
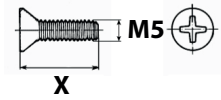

* Not supplied -

C CONNECTIONS

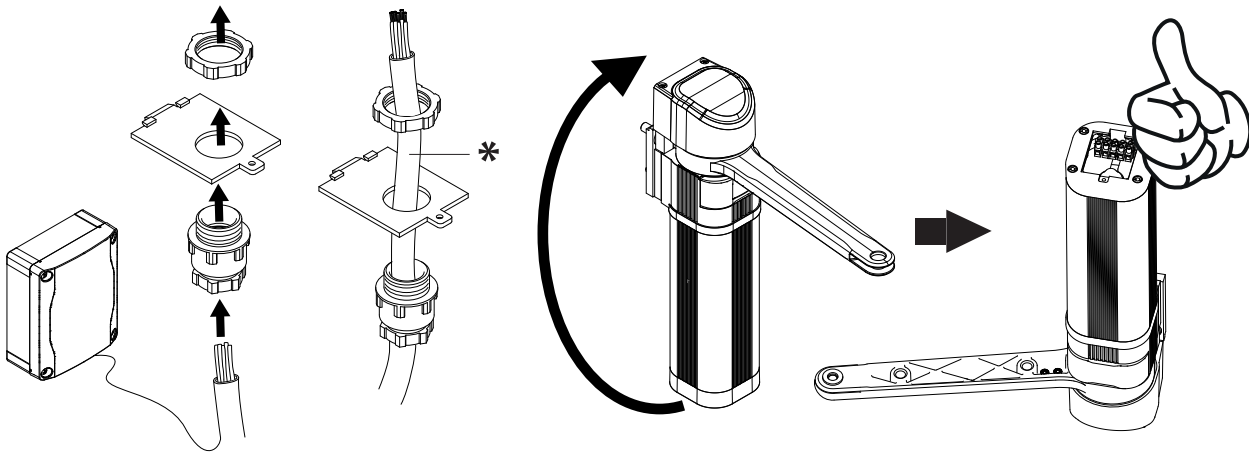

* Not supplied. Recommended H05RN-F

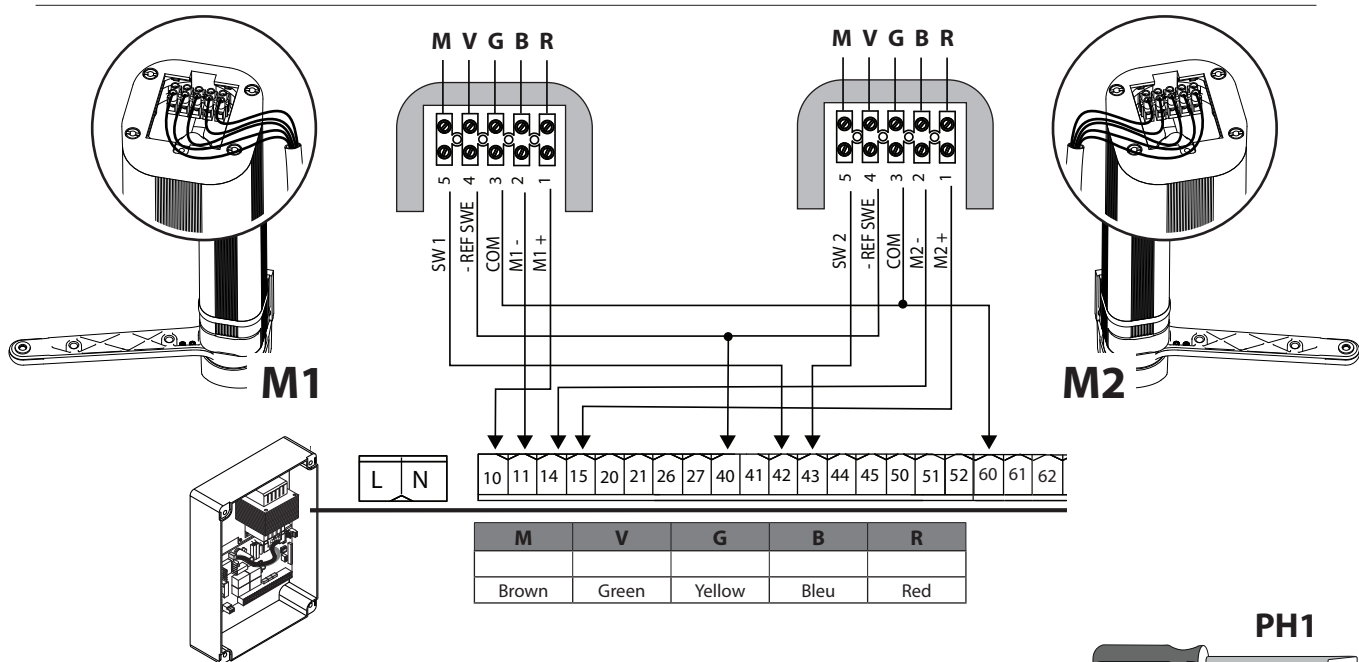

PH1

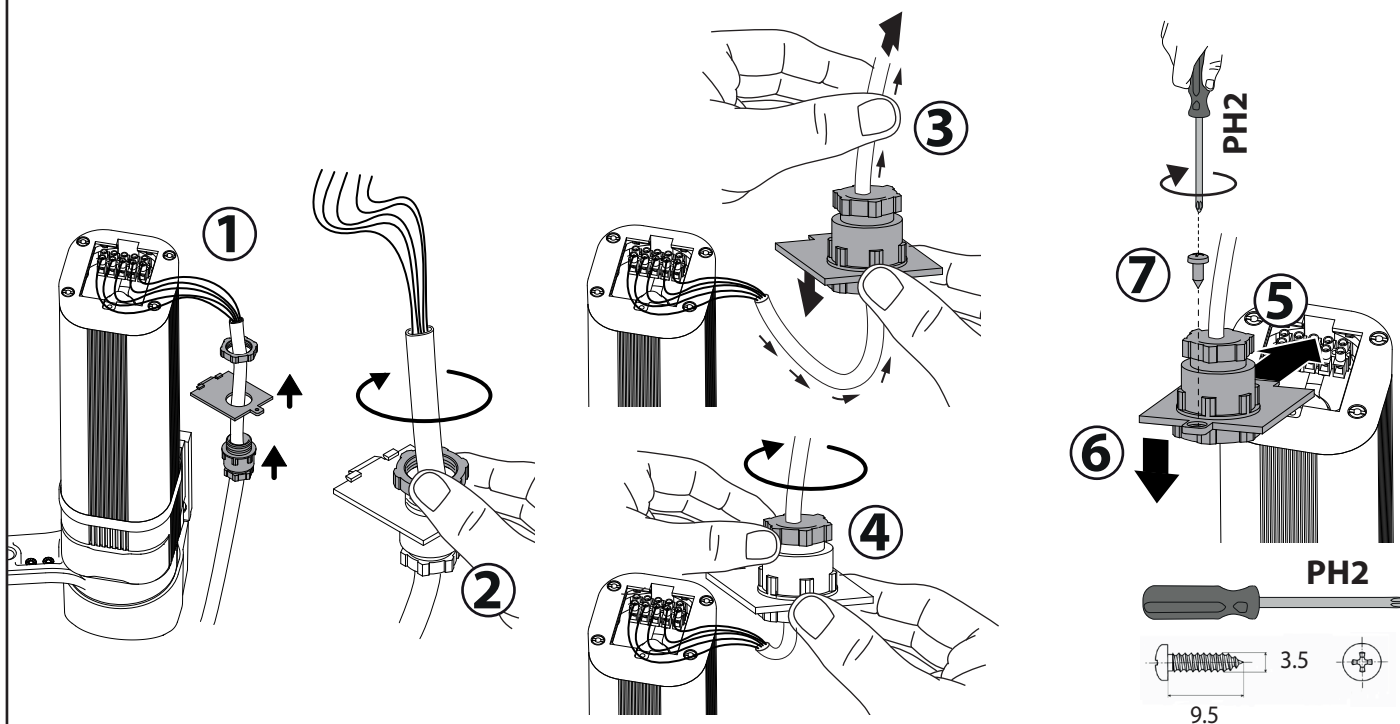

PH2

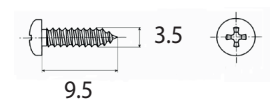

D

MOTOR INSTALLATION

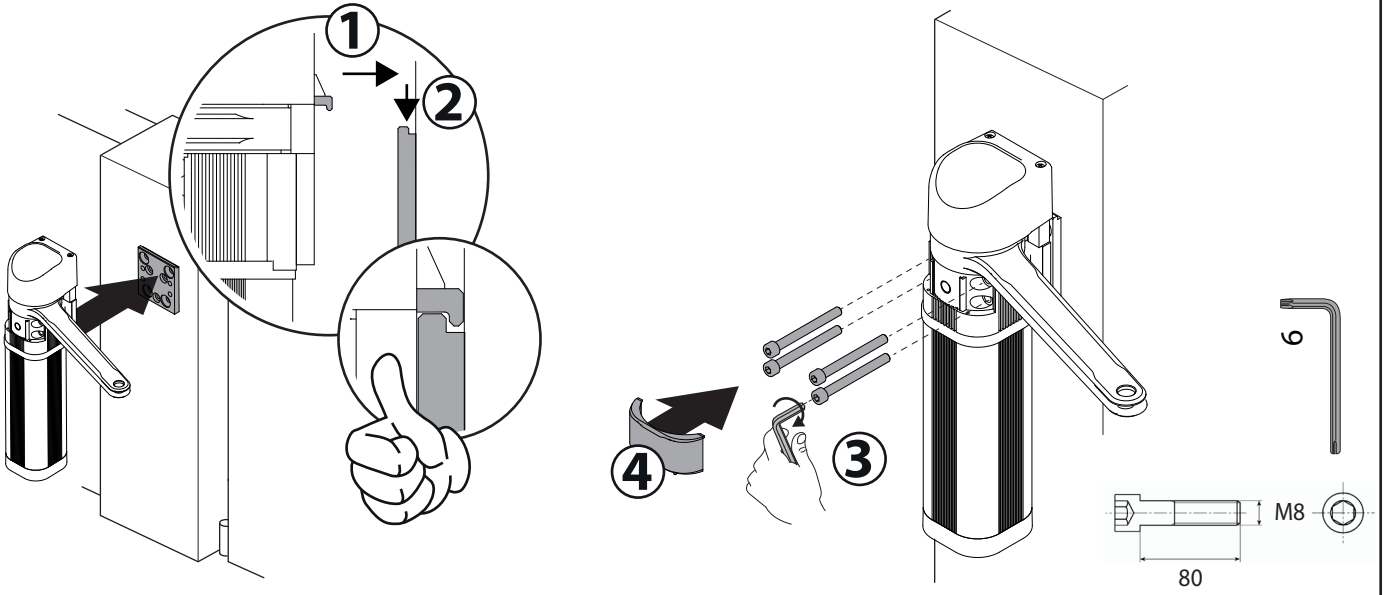

E

ASSEMBLY AND FASTENING OF ARTICULATED ARM

E5 BT A18

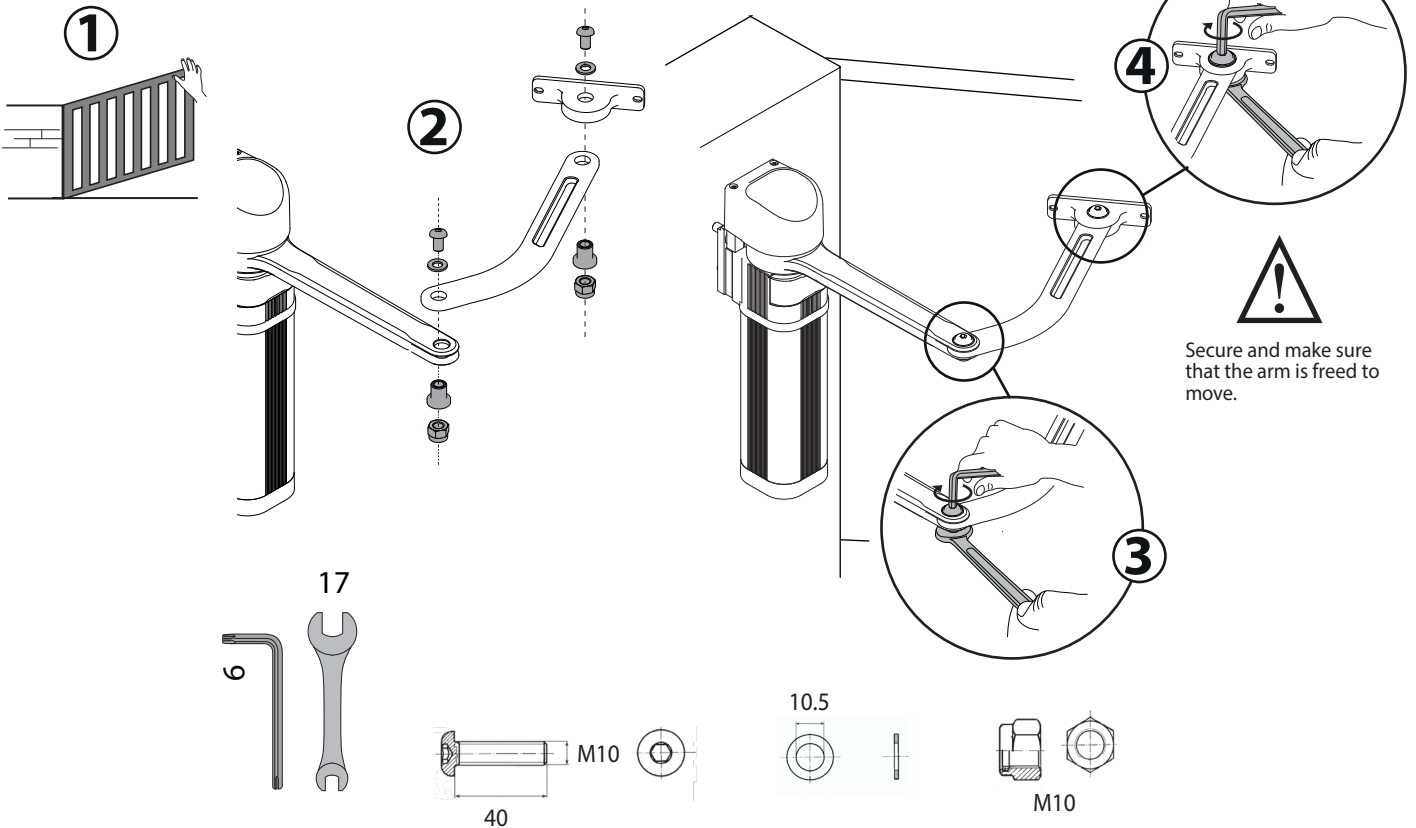

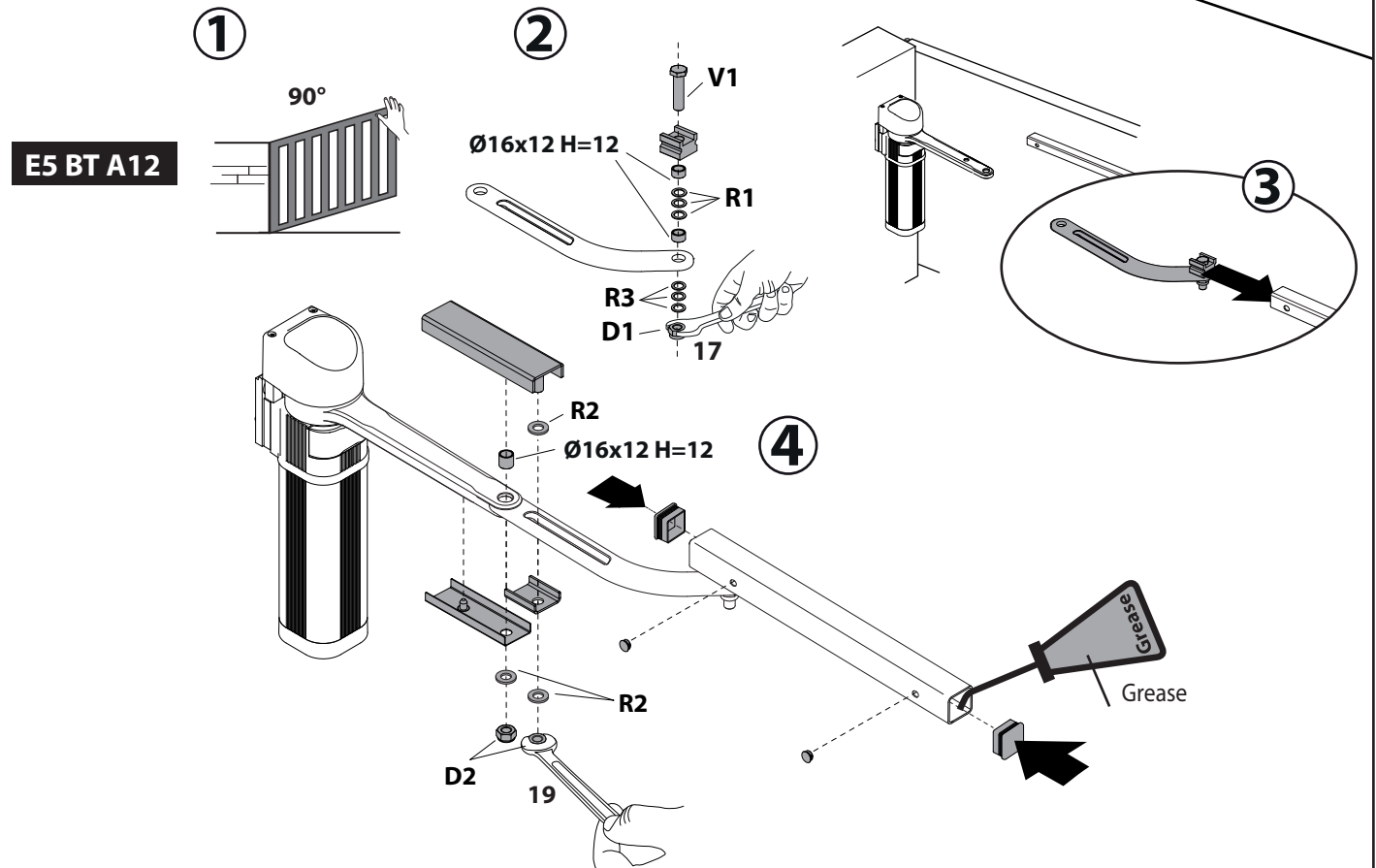
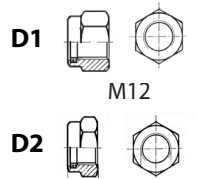
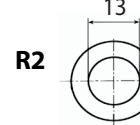
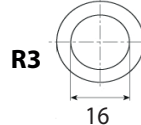
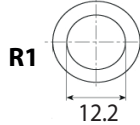
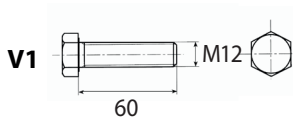
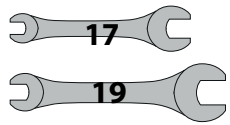
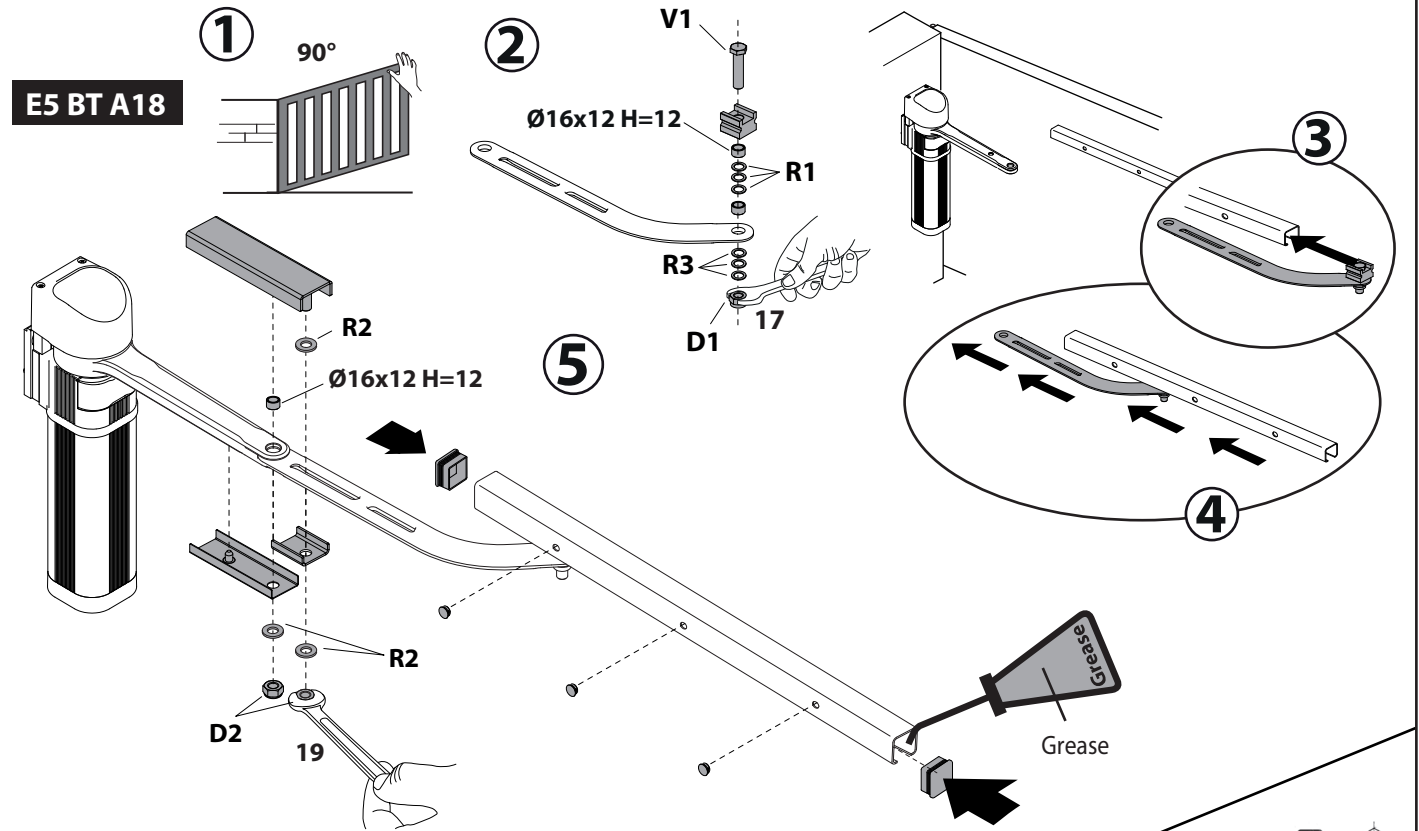
F**ASSEMBLY AND FASTENING OF SLIDE ARM**

TECHNICAL DATA

	E5 BT A 18	E5 BT A 12
Motor power supply	24 Vdc	
Maximum power	100W	
Length of leaf for maximum weight	1.8 m	1.2 m
Maximum leaf weight	100 kg	80 kg
Maximum leaf length	1.8 m	1.2 m
Maximum motor rpm	2500	1600
Opening time at 90° without load	14s	4.6 - 6.5s
Block holding	reversible gear motor	
Max. motor torque	150 Nm	40 Nm
Max. opening angle	130°	
Reaction to collision	multiple disk mechanical clutch	
Manual manoeuvre	electric lock release with key	
Max. No. of manoeuvres/h	20	100
Environmental conditions	-20 / +55° C	
Lubrication	permanent grease	
Degree of protection	IP44	
Actuator weight	50 N (5kg)	50 N (5kg)
Sound pressure	<70dB(A)	

* special voltage supplies on request

only for E5 BT A18

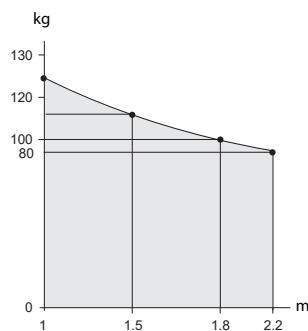

G

CLUTCH FASTENING

